

Summer Fling

Hunt Seat Equitation (Non Pro & Youth Classes)

Show Date: August 9-11, 2024

w w w . H o r s e S h o w P a t t e r n s . c o m

w w w . H o r s e S h o w P a t t e r n s . c o m

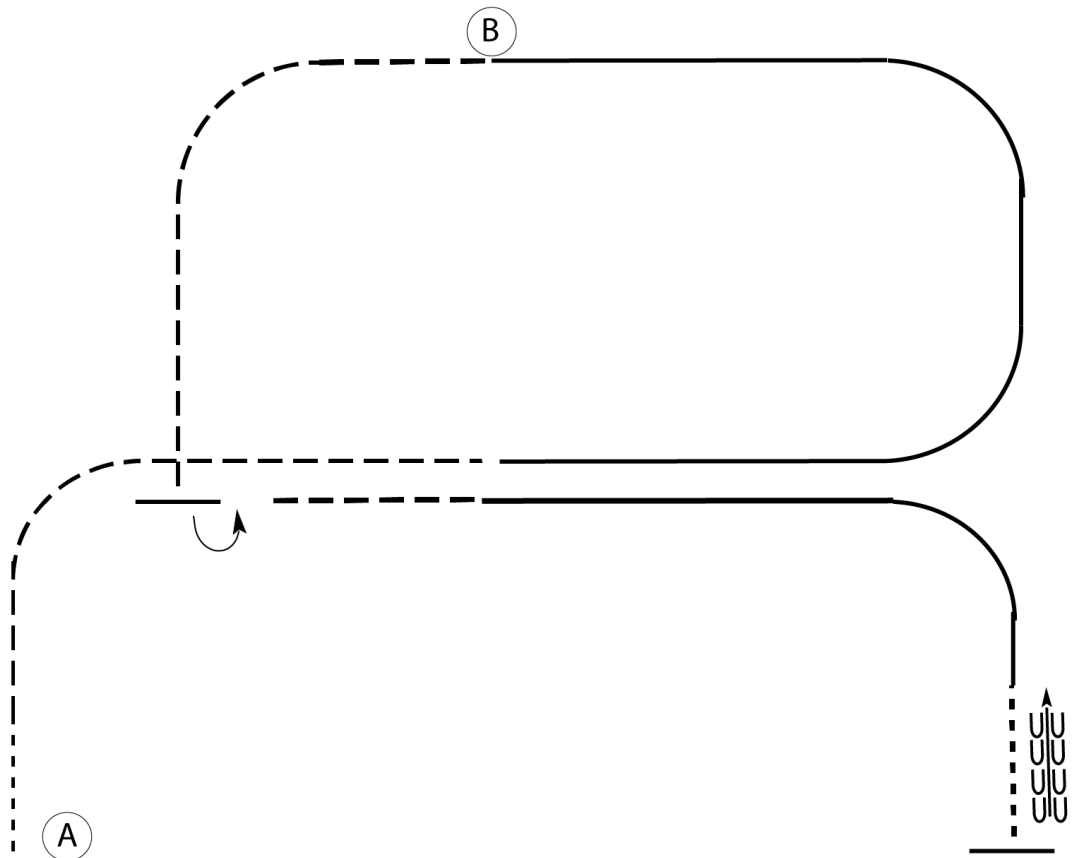

Be ready at A.

1. Forward walk for approximately 2 strides.
2. Trot on the left diagonal to center of pattern.
3. Canter on the left lead to B.
4. Trot on the right diagonal until halfway to A.
5. Stop and perform a 90 degree turn on the forehand to the left to change direction.
6. Sitting trot for 2-3 strides.
7. Canter on the right lead around corner.
8. Forward walk until even with A.
9. Stop and back.

Pattern is complete.

Walk	-----
Trot	- - - - -
Extended Trot	-----
Canter	—————
Leg Yield	
Lead Change	↙ ↘
Back	← ← ← ← ←
Marker	⊙
Sidepass	← ← ← ← ←
Hand Gallop	—————

[HSE/1-115]

Pattern Provided by:

Cheryl Ogle

Summer Fling

Saddle Seat Equitation (Youth & Non Pro)

Show Date: August 9-11, 2024

w w w . H o r s e S h o w P a t t e r n s . c o m

w w w . H o r s e S h o w P a t t e r n s . c o m

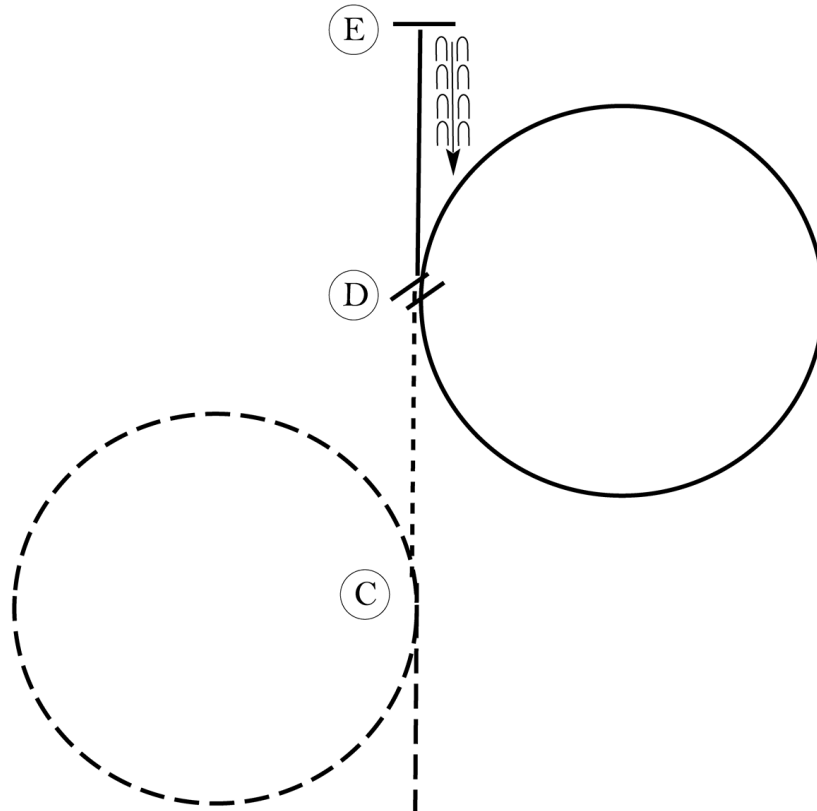

Be ready at A.

1. Sitting trot to B.
2. Posting trot on the left diagonal to C. (B)
3. Change diagonals and circle to the left at C.
4. Walk from C to D.
5. Canter a circle to the right at D.
6. Change leads at D and canter to E.
7. Stop at E and back approximately one horse length.

Exit at a trot.

Follow the instructions of your ring steward.

Walk	-----
Trot	- - - - -
Extended Trot	— — — — —
Canter	—————
Leg Yield	
Lead Change	↙ ↘
Back	← ← ← ← ←
Marker	(B)
Sidepass	← — — — — →
Hand Gallop	— — — — —

[HSE/2-39]

Pattern Provided by:

Cheryl Ogle

Summer Fling

Hunt Seat Equitation (Walk Trot Youth & NonPro)

Show Date: August 9-11, 2024

w w w . H o r s e S h o w P a t t e r n s . c o m

w w w . H o r s e S h o w P a t t e r n s . c o m

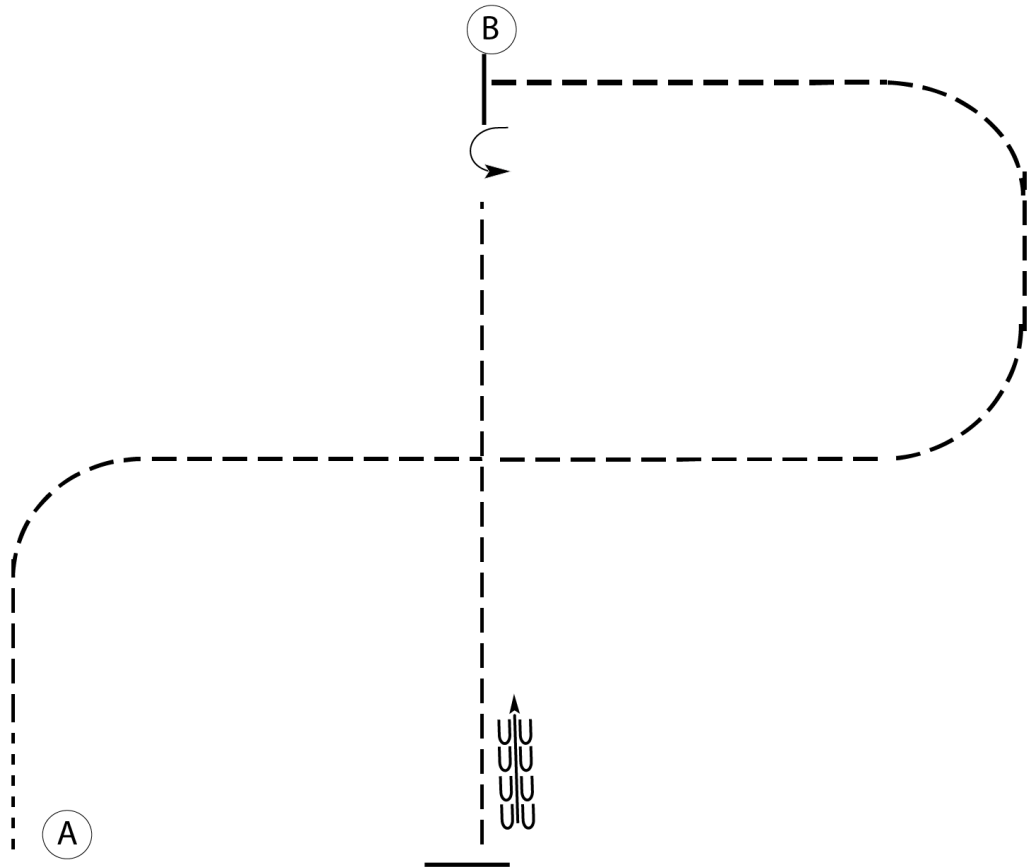

Be ready at A.

1. Forward walk for approximately 2 strides.
2. Trot on the left diagonal to center of pattern.
3. Change diagonals and trot on the right diagonal until even with B.
4. Stop and perform a 90 degree turn on the forehand to the left to change direction.
5. Sitting trot for 2-3 strides.
6. Trot on the left diagonal until even with A.
7. Stop and back.

Pattern is complete.

Walk	-----
Trot	- - - - -
Extended Trot	-----
Canter	—————
Leg Yield	
Lead Change	↙ ↘
Back	← ← ← ← ←
Marker	⊙
Sidepass	← — — — — →
Hand Gallop	—————

[HSE/WT-115]

Pattern Provided by:

Cheryl Ogle

Summer Fling

Reining (All Classes)

Show Date: August 9-11, 2024

REINING PATTERN 6

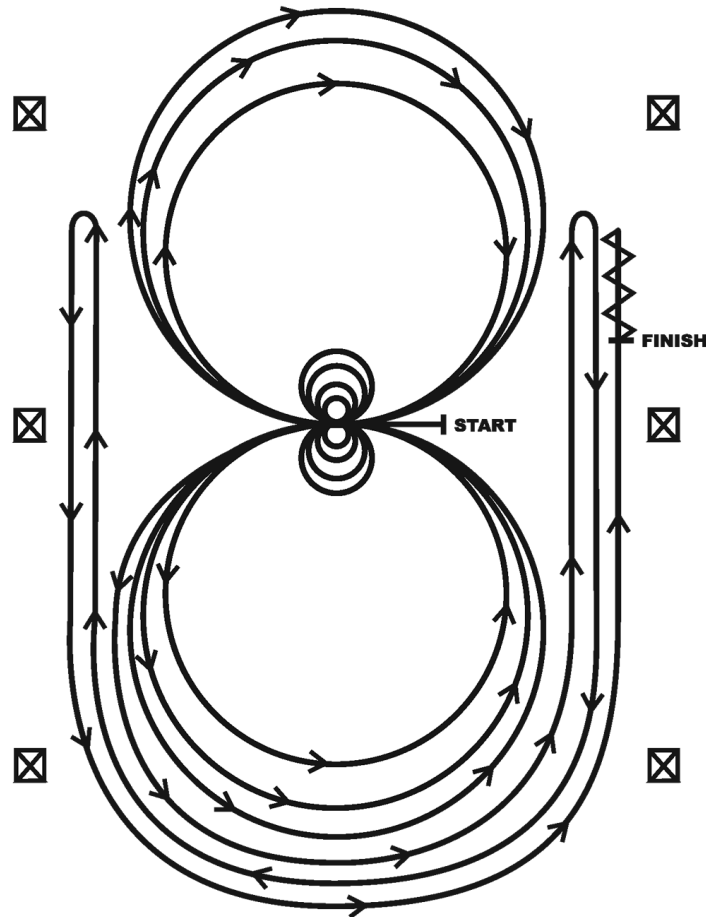

Horses may walk or jog to the center of arena. Horses must walk or stop prior to starting pattern. Beginning at the center of the arena facing the left wall or fence.

1. Complete four spins to the right. Hesitate.
2. Complete four spins to the left. Hesitate.
3. Beginning on the left lead, complete three circles to the left: the first two circles large and fast; the third circle small and slow. Change leads at the center of the arena.
4. Complete three circles to the right: the first two circles large and fast; the third circle small and slow. Change leads at the center of the arena.
5. Begin a large circle to the left but do not close this circle. Run up the right side of the arena past the center marker and do a right rollback at least twenty feet (six meters) from the wall or fence—no hesitation.
6. Continue back around previous circle but do not close this circle. Run up the left side of the arena past the center marker and do a left rollback at least twenty feet (six meters) from the wall or fence—no hesitation.
7. Continue back around previous circle but do not close this circle. Run up the right side of the arena past the center marker and do a sliding stop at least twenty feet (six meters) from the wall or fence. Back up at least ten feet (three meters). Hesitate to demonstrate the completion of the pattern.

[R/AQHAP-6]

Pattern Provided by:

Cheryl Ogle

Summer Fling

English Showmanship (Youth 18 & Under)

Show Date: August 9-11, 2024

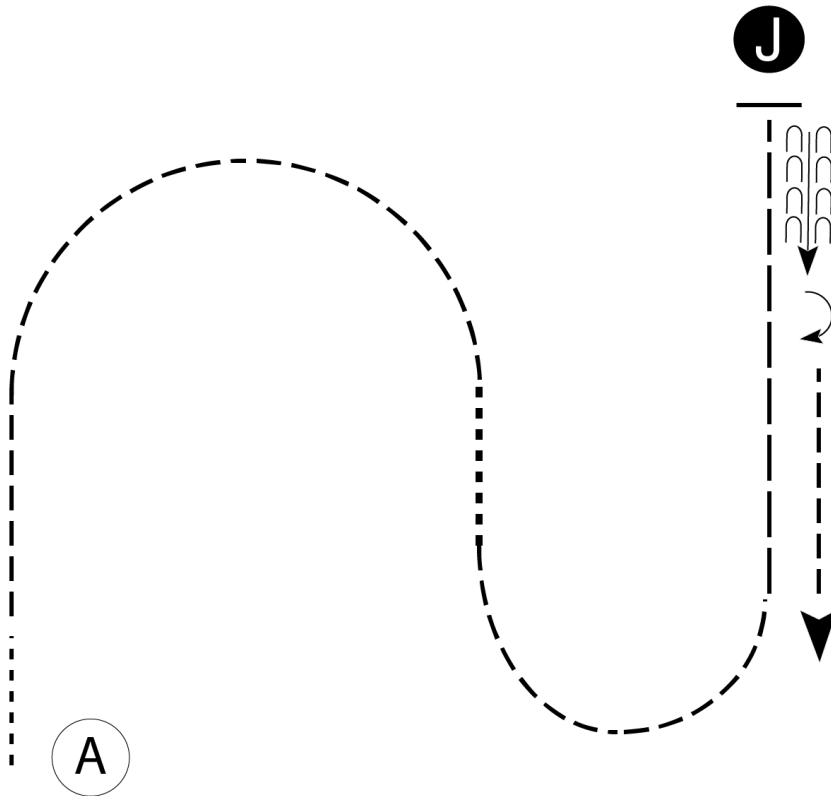

Be ready at A.

1. Walk FORWARD two horse lengths then trot.
2. Trot half circle.
3. Walk FORWARD one horse length.
4. Trot in a half circle.
5. Extended trot to Judge and stop.
6. Set up.
7. Inspection.
8. When dismissed, back approximately two horse lengths.
9. Perform a 180 degree turn and trot to exit.

Walk	-----
Trot	- - - - -
Back	←
Marker	ⓐ
Judge	ⓙ

[S/1-122]

Pattern Provided by:

Cheryl Ogle

Summer Fling

Western Showmanship (WT Youth & NP, Novice Youth & Novice NP)

Show Date: August 9-11, 2024

w w w . H o r s e S h o w P a t t e r n s . c o m

w w w . H o r s e S h o w P a t t e r n s . c o m

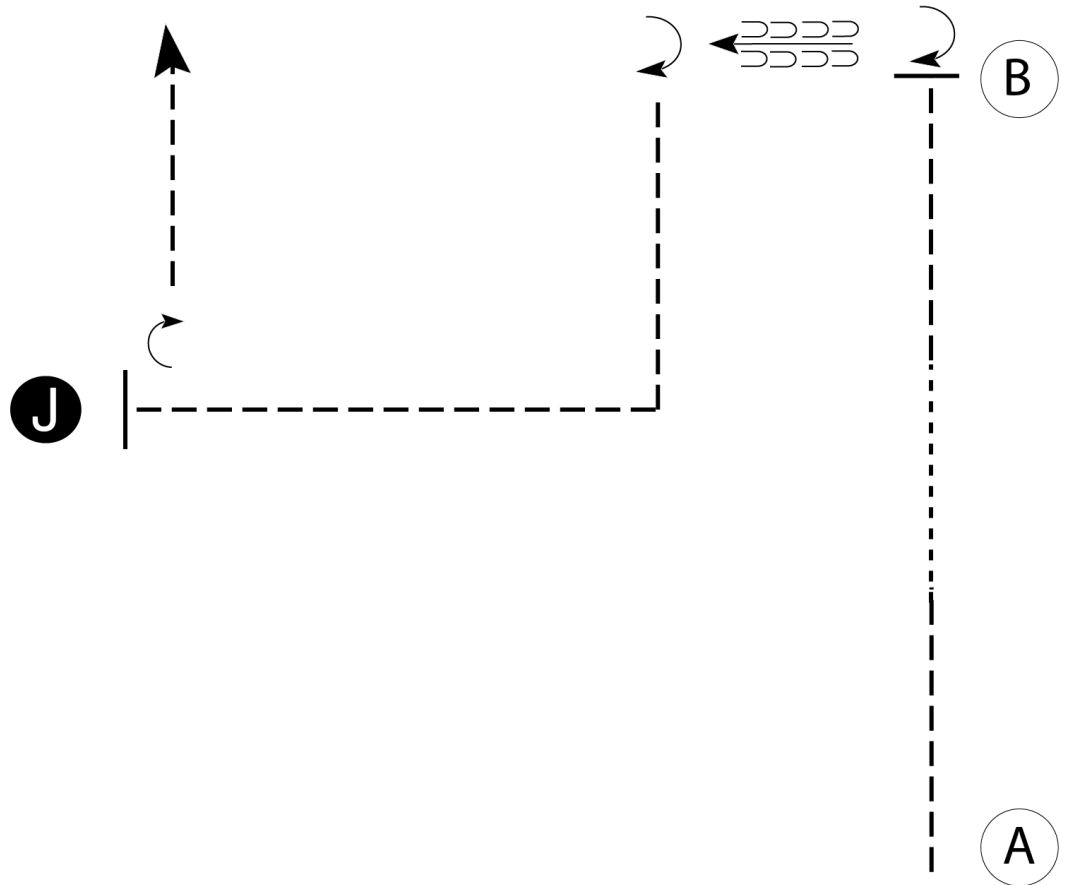

Be ready at A.

1. Trot 1/3 of the line, then walk 1/3 of the line then trot the final 1/3 of the line.
2. Stop with horse's hip even with B then perform a 1/4 turn.
3. Back 2 horse lengths then perform a 1/4 turn.
4. Trot to judge as shown.
5. Stop and set up at Judge.
6. Inspection.
7. When dismissed, perform a 1/4 turn and trot to exit.

Walk -----
Trot - - - - -
Back ← 〰〰〰〰〰
Marker (B)
Judge (J)

[S/1-119]

Pattern Provided by:

Cheryl Ogle

Summer Fling

Western Showmanship (35 & Over NP, NP, Masters, Youth 13 & U, 14-18)

Show Date: August 9-11, 2024

w w w . H o r s e S h o w P a t t e r n s . c o m

w w w . H o r s e S h o w P a t t e r n s . c o m

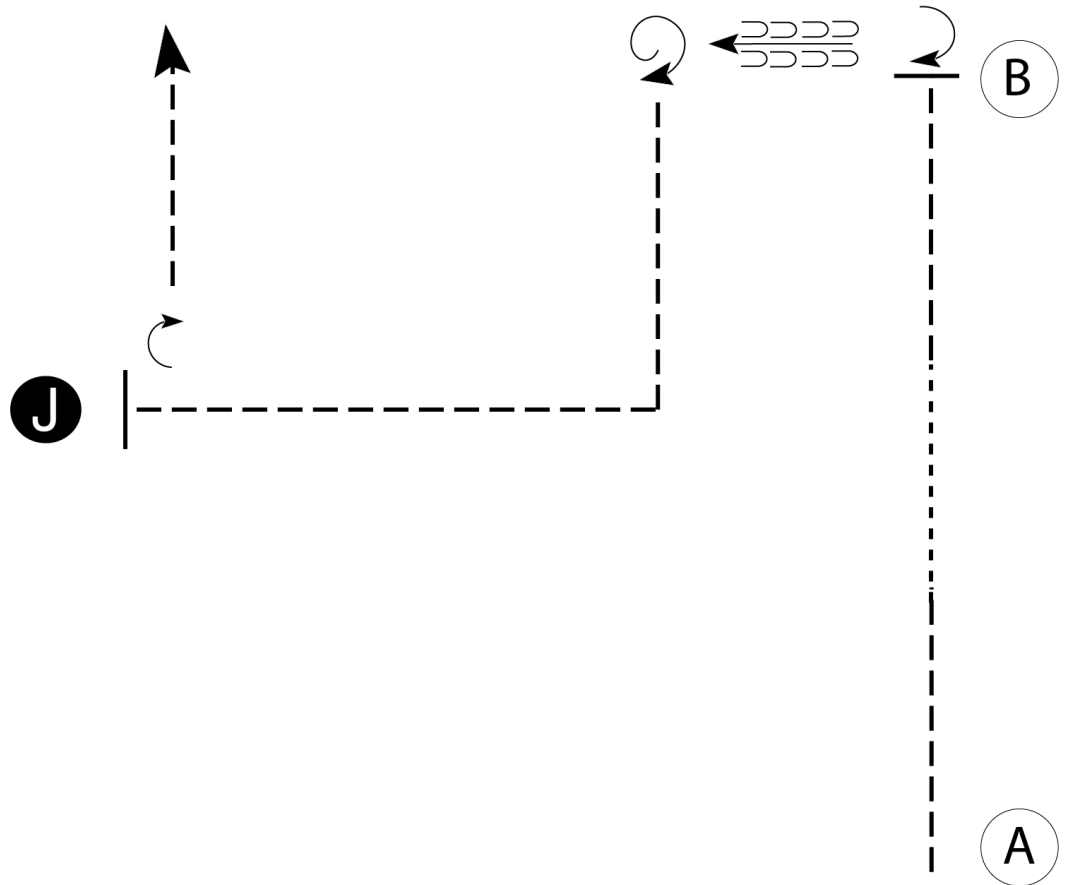

Be ready at A.

1. Trot 1/3 of the line, then walk 1/3 of the line then trot the final 1/3 of the line.
2. Stop with horse's hip even with B then perform a 1/4 turn.
3. Back 2 horse lengths then perform a 1 1/4 turn.
4. Trot to judge as shown.
5. Stop and set up at Judge.
6. Inspection.
7. When dismissed, perform a 1/4 turn and trot to exit.

Walk -----
Trot - - - - -
Back ← ← ← ← ←
Marker (B)
Judge (J)

[S/2-119]

Pattern Provided by:

Cheryl Ogle

Summer Fling

Western Horsemanship (All Youth & Non Pro)

Show Date: August 9-11, 2024

w w w . H o r s e S h o w P a t t e r n s . c o m

w w w . H o r s e S h o w P a t t e r n s . c o m

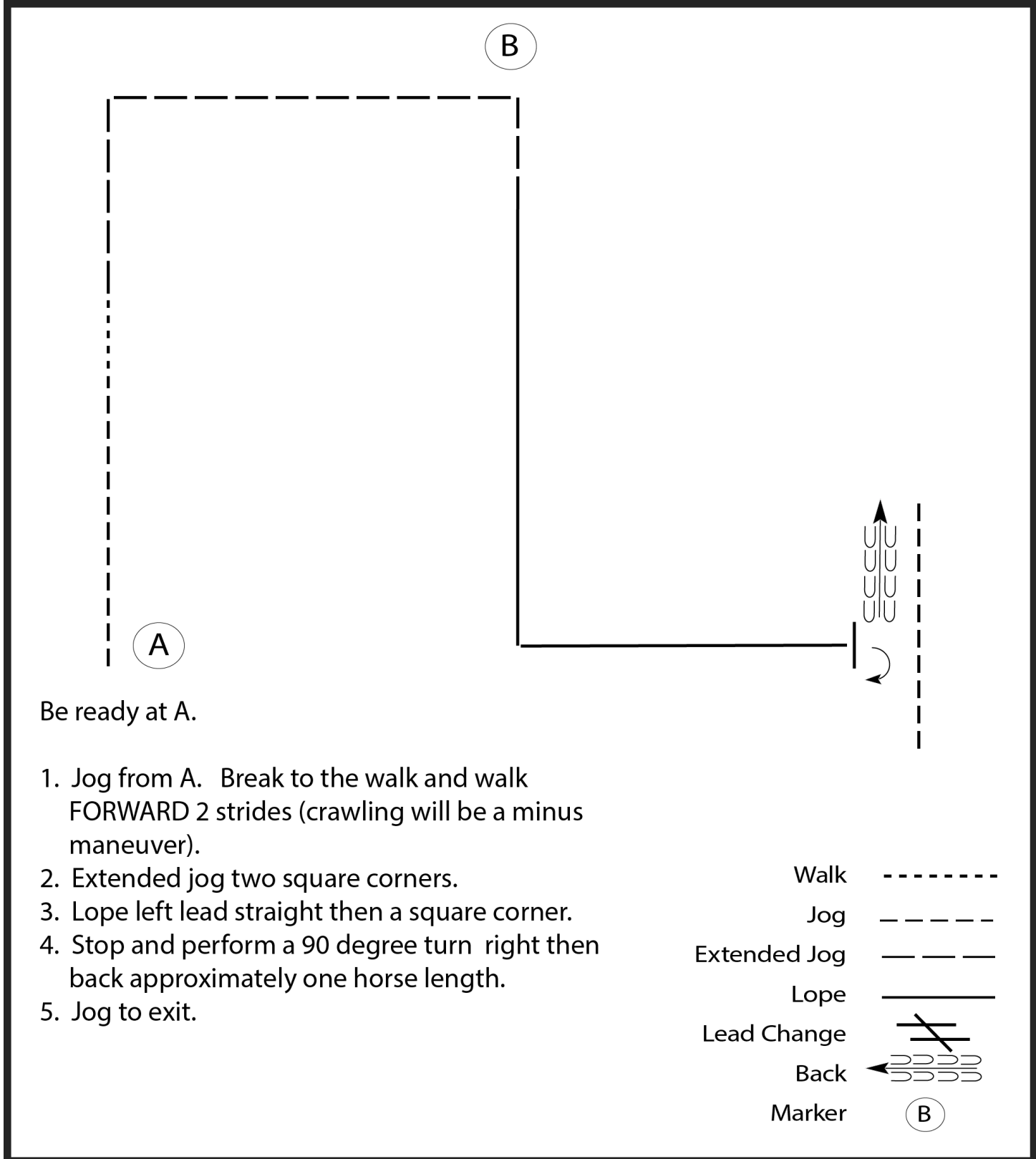

Be ready at A.

1. Jog from A. Break to the walk and walk FORWARD 2 strides (crawling will be a minus maneuver).
2. Extended jog two square corners.
3. Lope left lead straight then a square corner.
4. Stop and perform a 90 degree turn right then back approximately one horse length.
5. Jog to exit.

- Walk -----
- Jog - - - - -
- Extended Jog - - - - -
- Lope _____
- Lead Change
- Back
- Marker (B)

[WH/1-120]

Pattern Provided by:
Cheryl Ogle

Summer Fling

Bareback Horsemanship (Youth & Non Pro)

Show Date: August 9-11, 2024

w w w . H o r s e S h o w P a t t e r n s . c o m

w w w . H o r s e S h o w P a t t e r n s . c o m

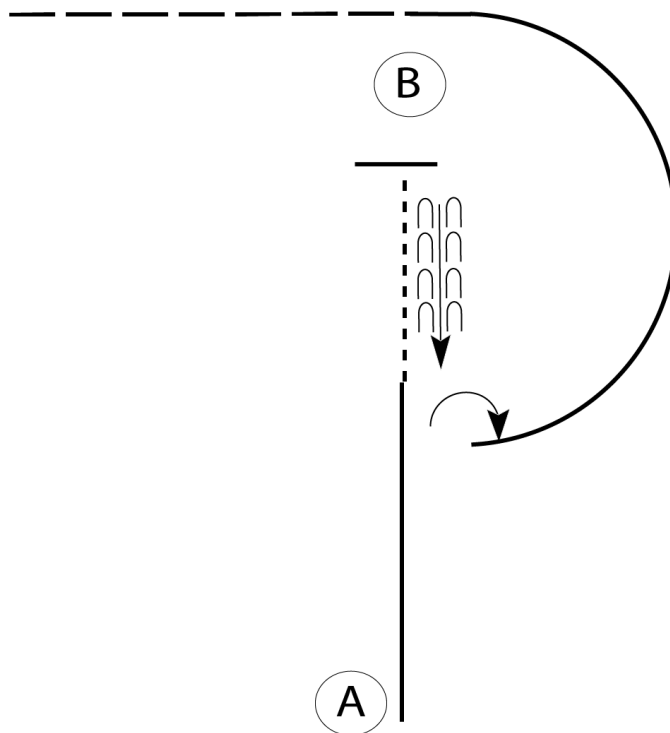

Be ready at A.

1. Lope right lead 3/4 the way to B.
2. Walk with FORWARD motion to B (crawling will be a minus maneuver) . Stop.
3. Back approximately 5 steps
4. Perform a 90 degree turn right.
5. Lope left lead in a half circle to the top of B.
6. Extended jog at least 6 strides. Pattern is complete.

Walk	-----
Jog	- - - - -
Extended Jog	- - - - -
Lope	—————
Lead Change	———/———
Back	←←←←←
Marker	(B)

[WH/2-119]

Pattern Provided by:

Cheryl Ogle

Summer Fling

Western Horsemanship (WT 10 & U, WT 11-18, WT Non Pro)

Show Date: August 9-11, 2024

w w w . H o r s e S h o w P a t t e r n s . c o m

w w w . H o r s e S h o w P a t t e r n s . c o m

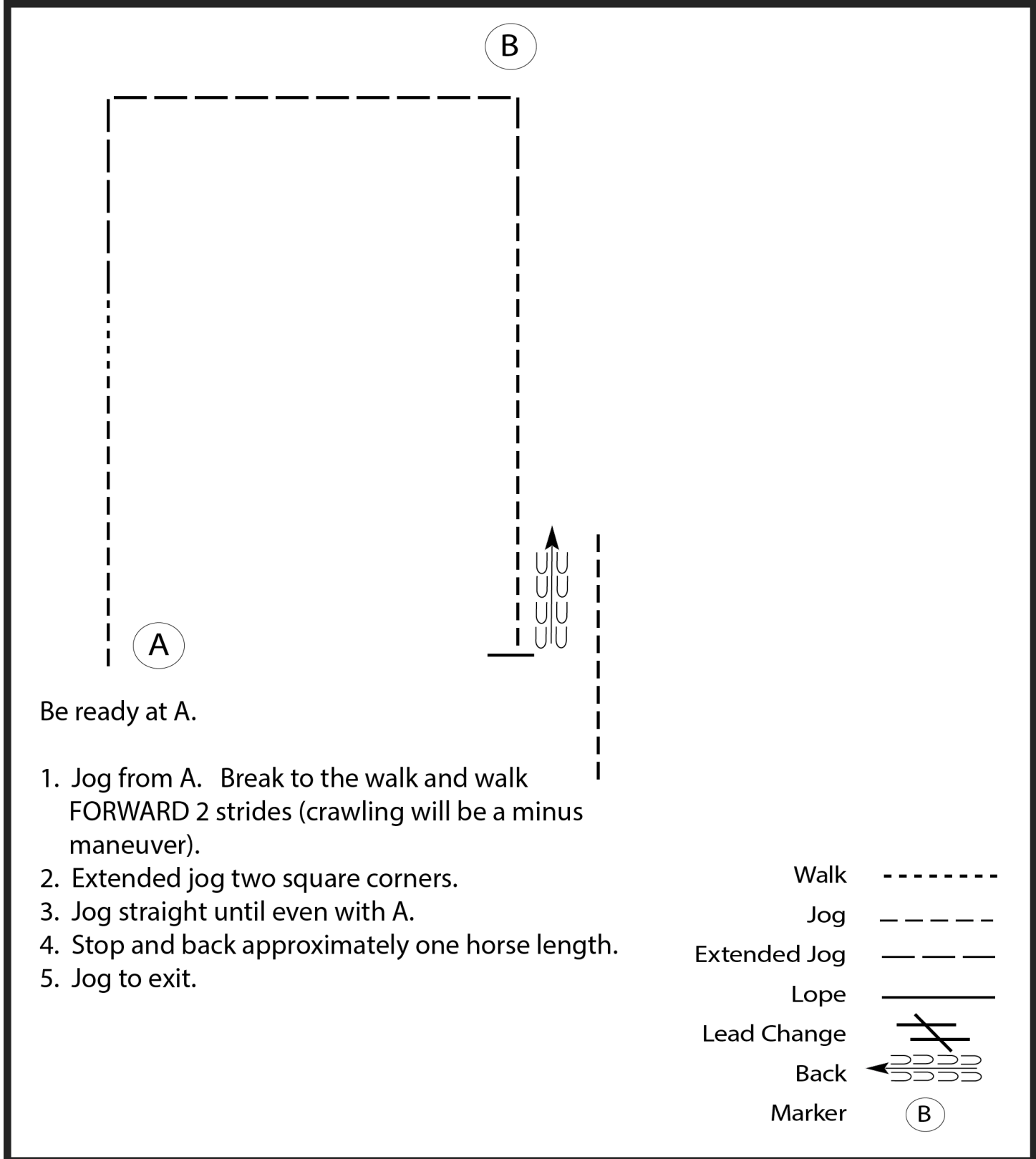

Be ready at A.

1. Jog from A. Break to the walk and walk FORWARD 2 strides (crawling will be a minus maneuver).
2. Extended jog two square corners.
3. Jog straight until even with A.
4. Stop and back approximately one horse length.
5. Jog to exit.

Walk	-----
Jog	- - - - -
Extended Jog	— — — —
Lope	—————
Lead Change	
Back	
Marker	(B)

[WH/WT-120]

Pattern Provided by:
Cheryl Ogle

Summer Fling

Western Riding (All Classes)

Show Date: August 9-11, 2024

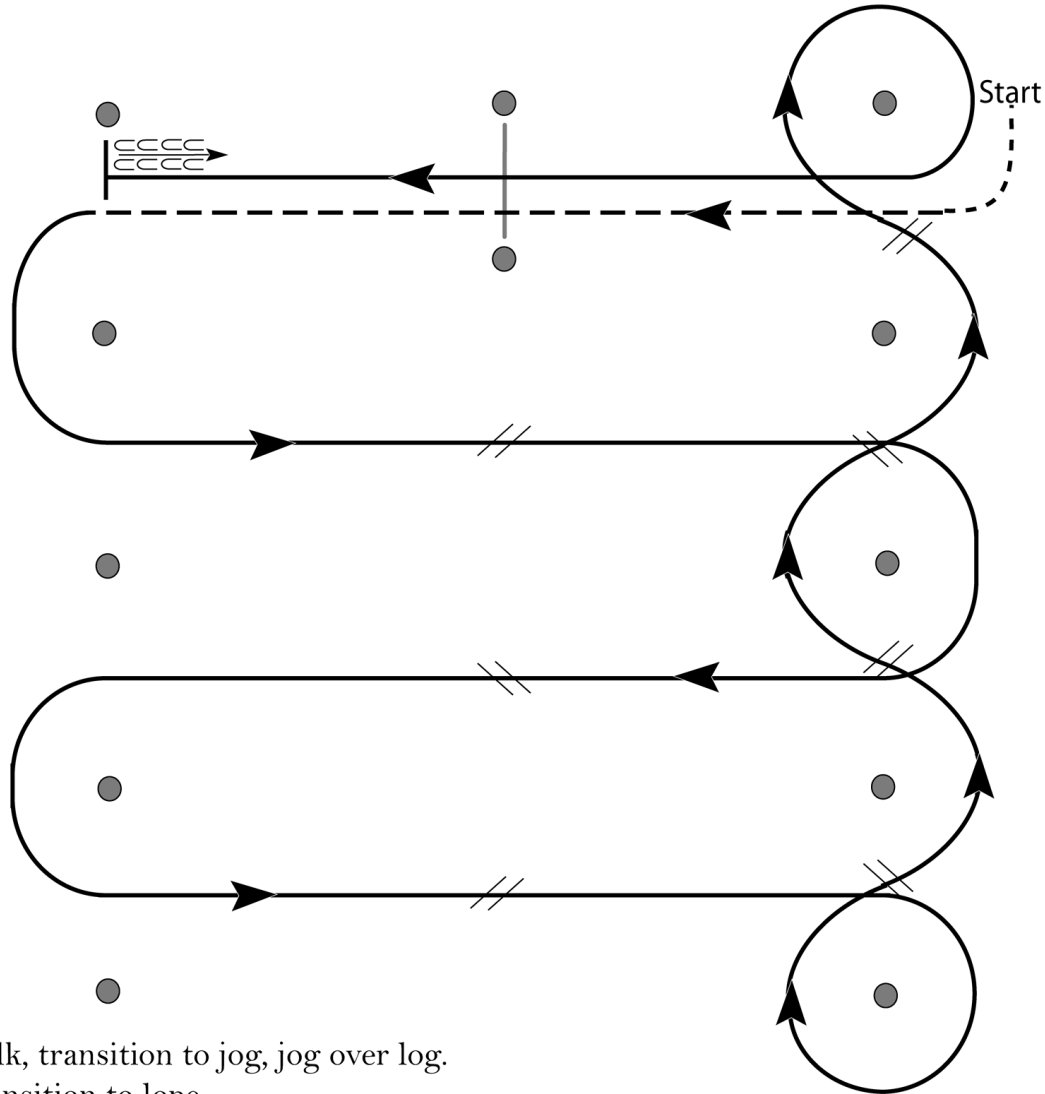

1. Walk, transition to jog, jog over log.
2. Transition to lope.
3. First crossing change.
4. Second crossing change.
5. Third crossing change.
6. Circle and first line change.
7. Second line change.
8. Third line change.
9. Fourth line change and circle.
10. Lope log.
11. Lope, stop and back.

[WR/OP-2]

Pattern Provided by:

Cheryl Ogle

Summer Fling

Working Cowhorse (All Classes)

Show Date: August 9-11, 2024

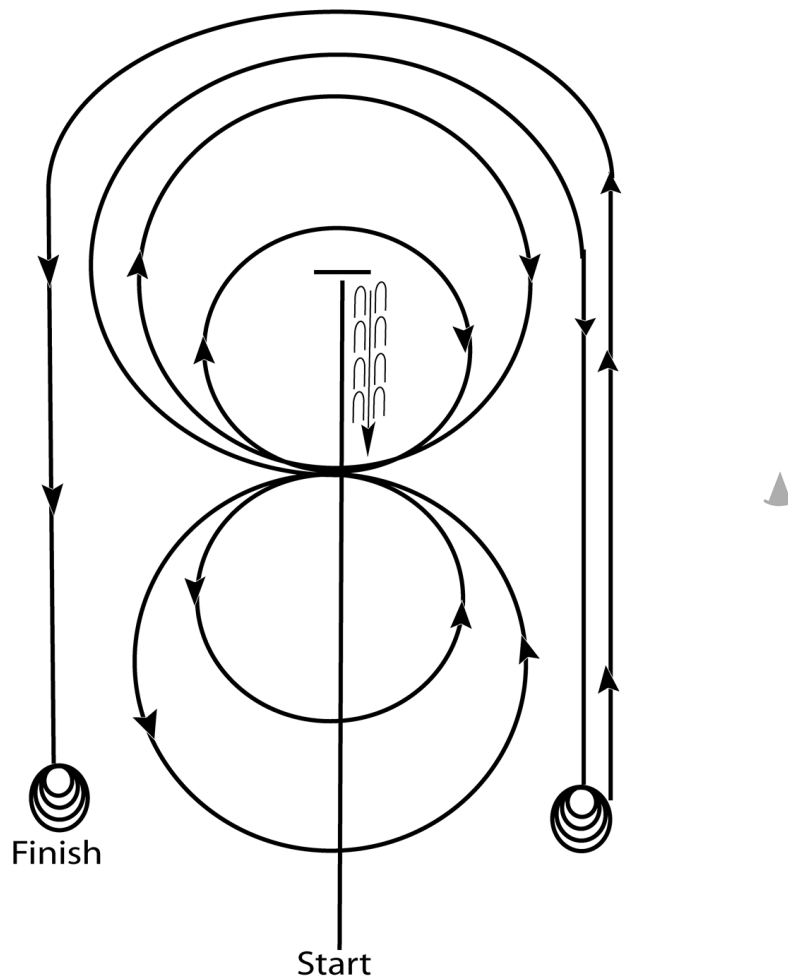

Pattern 1

1. Start at end of arena. Run down middle past center marker to a sliding stop.
2. Back at least 10 feet to center. 1/4 turn left.
3. Pickup right lead, big fast circle, small slow circle.
4. Change leads to left, big fast circle, small slow circle.
5. Change leads to right, do not close this circle.
6. Run around end of arena and down the side (approximately 20 feet from fence) past center marker and come to a sliding stop.
7. Complete 3 1/2 turns to the right.
8. Continue back down side and end of arena to other side (approximately 20 feet from fence) go past center marker and come to a sliding stop.
9. Complete 3 1/2 turns to the left.
10. Hesitate to complete pattern.

[NRCHAWC/1]

Pattern Provided by:

Judges

Summer Fling

Ranch Riding (Walk Trot (trot for lope, XTrot for XLope))

Show Date: August 9-11, 2024

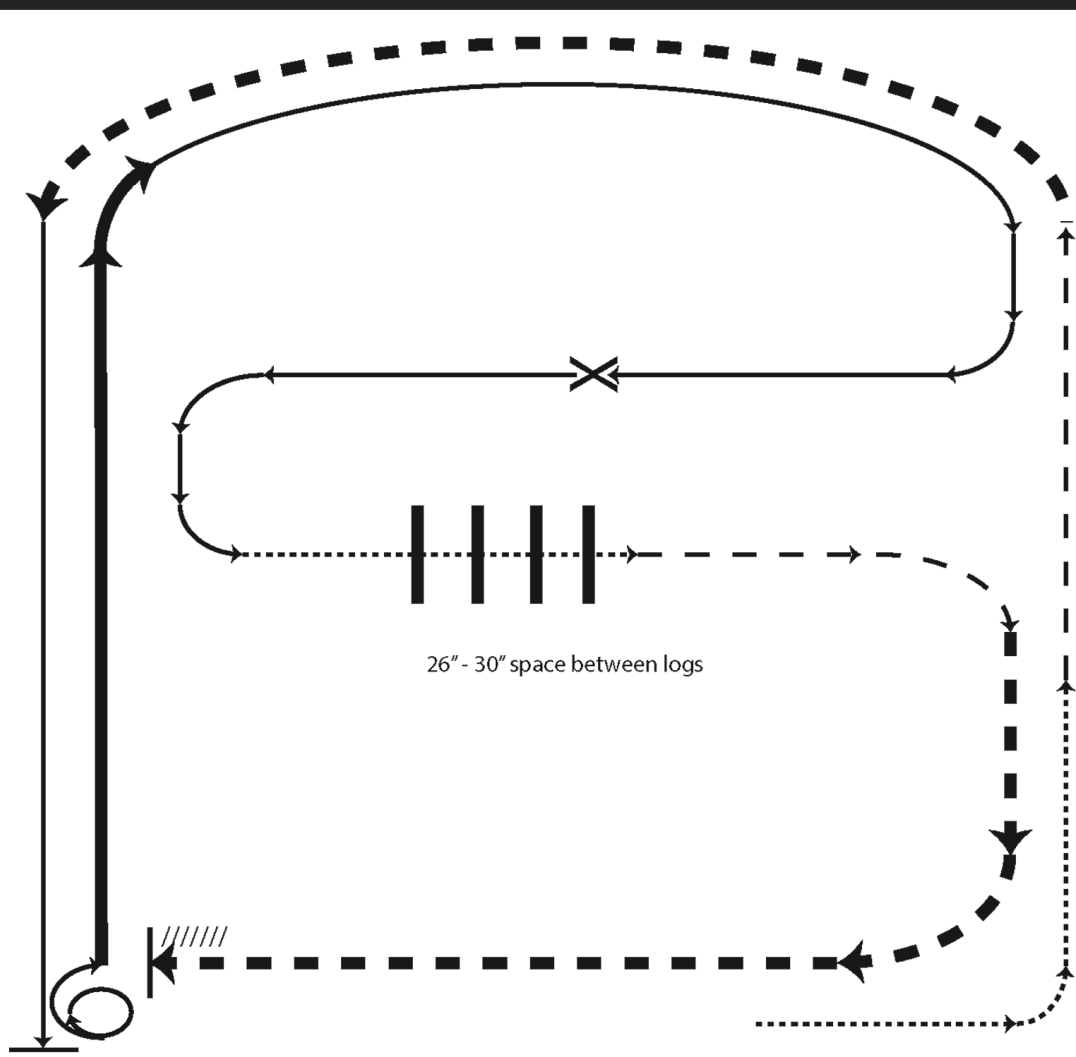

- X Lead Change
- Walk
- - - Trot
- - - Ext Trot
- — — Lope
- — — Ext Lope
- /////// Back

1. Walk
2. Trot
3. Extended trot
4. Left lead lope
5. Stop, 1 1/2 turn right
6. Extended lope
7. Collect to working lope-right lead
8. Change leads (simple or flying)
9. Walk
10. Walk over logs
11. Trot
12. Extended trot
13. Stop and back

[RR/AQHA-2]

Pattern Provided by:

Judges

www.HorseShowPatterns.com

www.HorseShowPatterns.com

Summer Fling

Ranch Reining

Show Date: August 9-11, 2024

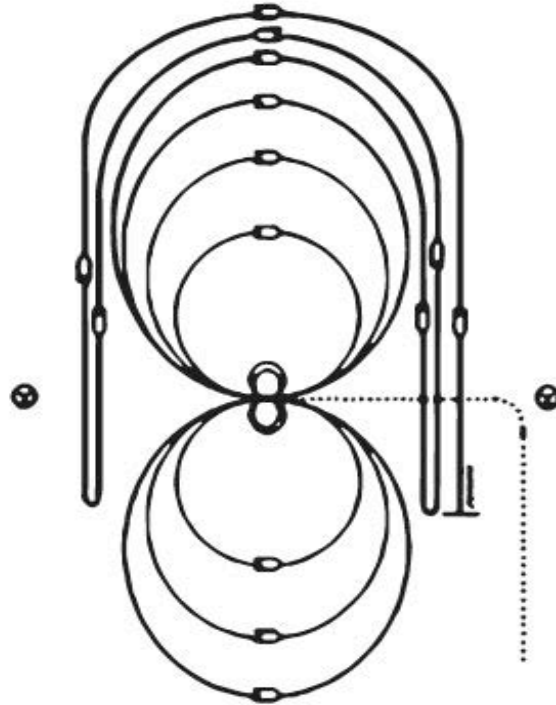

RANCH REINING PATTERN 2

Mandatory Markers along Fence or Wall: The judge shall indicate with markers on arena fence or wall the center of pattern.

Ride pattern as follows: Trot to center of arena and stop or walk before departure.

1. Beginning on right lead, complete two circles to the right - the first one large and fast; the second one small and slow. Stop at center.
2. Complete 4 spins to the right. Hesitate.
3. Beginning on left lead, complete two circles to the left - the first one large and fast; the second one small and slow. Stop at center.
4. Complete 4 spins to the left. Hesitate.
5. Beginning on the right lead, complete a large fast circle to the right and change leads at center of arena. Complete a large fast circle to the left and change leads at center of arena.
6. Begin a large fast circle to the right, but do not close this circle. Run down the right side of the arena, past the center marker, and do a left roll back at least 20 feet from the wall or fence.
7. Continue back around the previous circle, but do not close this circle. Run down the left side of the arena, past the center marker, and do a right roll back at least 20 feet from the wall or fence.
8. Continue back around previous circle, but do not close this circle. Run down right side of the arena, past the center marker, and do a sliding stop at least 20 feet from the wall or fence. Back up at least 10 feet. Hesitate to show completion of pattern.

226 Appaloosa Horse Club www.appaloosa.com

Pattern Provided by:

Judges

Trail - All Classes

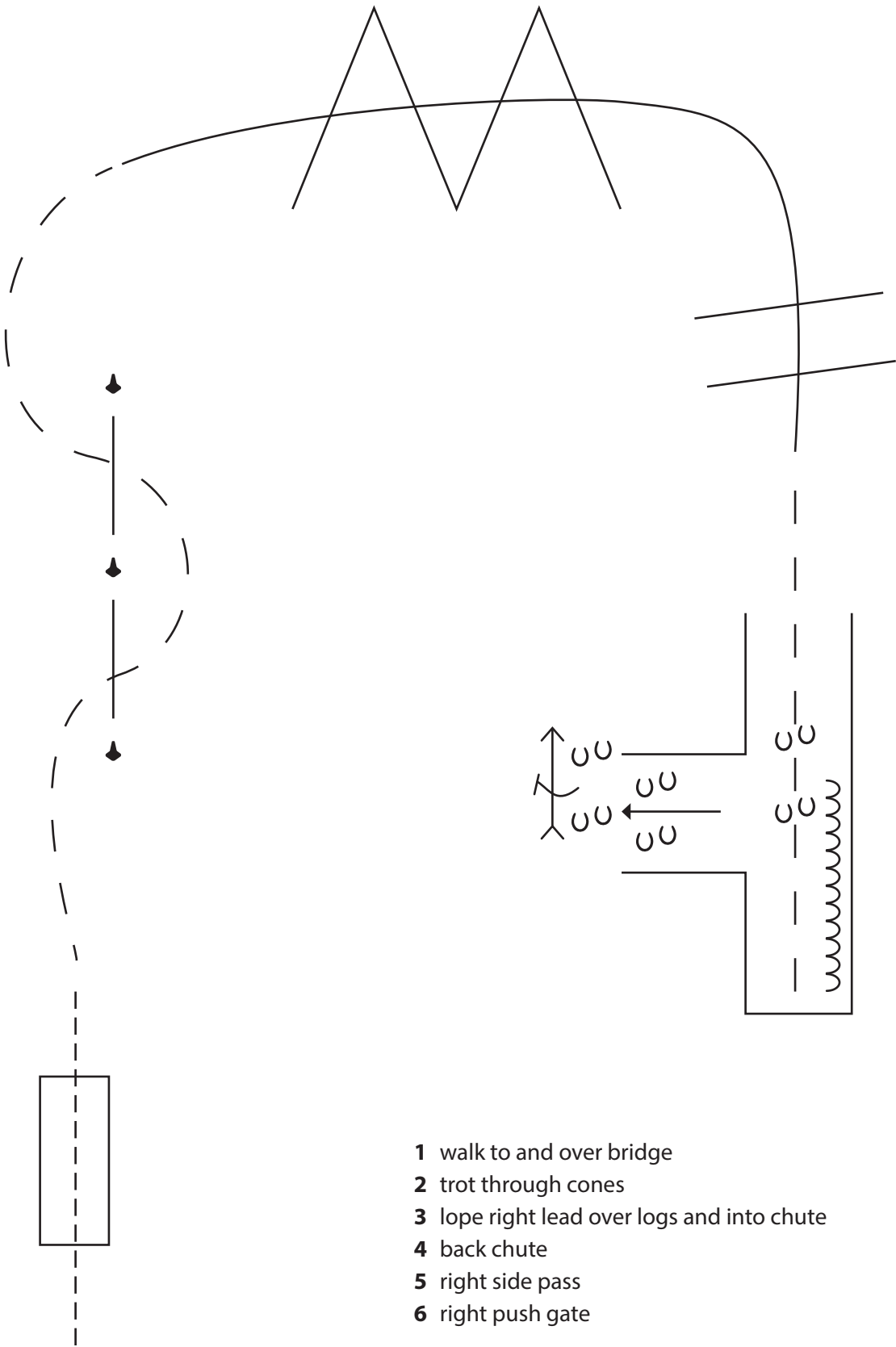

Walk Trot will trot where the lope is indicated

Ranch Trail - All Classes

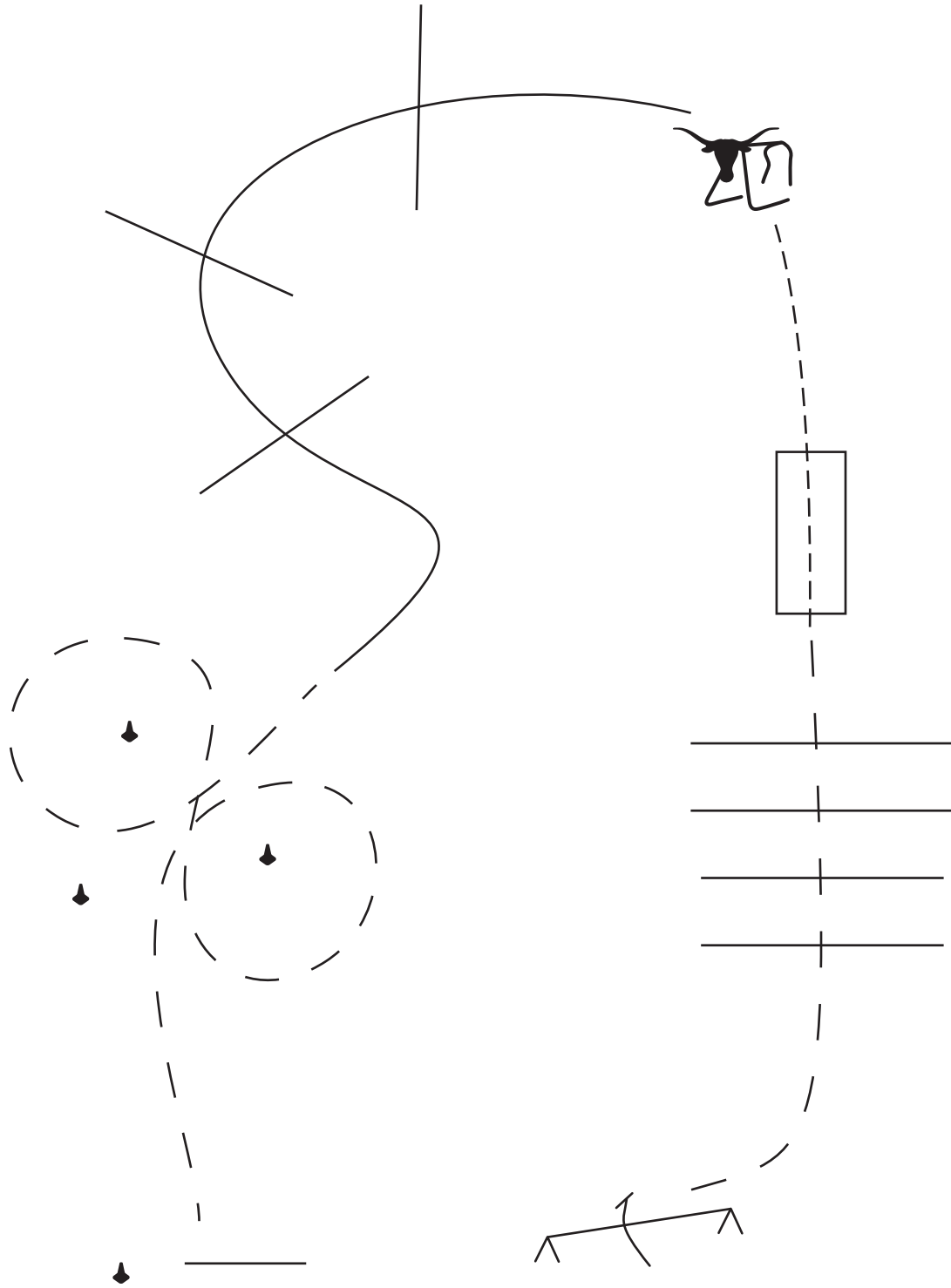

- 1 right hand push gate
- 2 trot over logs
- 3 walk over bridge to steer
- 4 rope steer
- 5 left lead over logs
- 6 extend trot through cones
- 7 at cone dismount and pick up 1 front foot

Walk Trot will trot where the lope is indicated